

- STYLE CODE (CHECK ONE)
- CELL SIDE MATERIAL:
- A DOUBLE TURN FLANGE 18 GA GAL (STANDARD)
 - B SINGLE FLANGE 18 GA GAL
 - C DOUBLE TURN FLANGE - .050 ALUM
 - D SINGLE FLANGE - .050 ALUM
 - E DOUBLE TURN FLANGE - 304 STAINLESS
 - F SINGLE FLANGE - 304 STAINLESS
 - G NFR PARTICLE BOARD (STANDARD)
 - H DOUBLE TURN FLANGE - 16 GA GAL
 - I SINGLE FLANGE - 16 GA GAL
 - J FR PARTICLE BOARD
 - K SINGLE HEADER 26 GA GAL (NON-TESTED)
 - L DOUBLE HEADER 26 GA GAL (NON-TESTED)
 - M NO HEADER - STRAIGHT BOX - 26 GA (NON-TESTED)
 - N FW PARTICLE BOARD
 - P PAN STYLE (C STYLE) 18 GA
 - Q PAN STYLE (C STYLE) .050 ALUMINUM
- FILTER MEDIA AND CAPACITY:
- 1 99.97% STANDARD CAPACITY
 - 2 99.97% HIGH CAPACITY
 - 3 99.99% STANDARD CAPACITY
 - 4 99.99% HIGH CAPACITY
 - 5 99.999% STANDARD CAPACITY
 - 6 99.999% HIGH CAPACITY
 - 7 95 DOP
 - 8 95 DOP HC
- SEPARATORS:
- X ALUMINUM (STANDARD)
 - Y PVC COATED ALUMINUM

- STYLE CODE (CHECK ONE)
- SEALANT MATERIAL:
- 1 POLYURETHANE FOAM (DTF, SBW ONLY)
 - 2 SOLID POLYURETHANE (ALL OTHERS)
 - 3 HIGH TEMP SILICONE (500 DEGREE)
 - 4 HOTMELT ADHESIVE (95 DOP, NHM, SH, DH ONLY)
 - 5 HIGH TEMP SILICONE (750 DEGREE)
- GASKET MATERIAL:
- DOVETAIL NEOPRENE (STANDARD) - 1/4 INCH
 - SILICONE - 1/4 INCH
 - HIGH TEMP ROPE - 1/4 INCH
 - NONE
- GASKET LOCATION:
- DOWNSTREAM (STANDARD ON ALL MODELS)
 - UPSTREAM
 - UPSTREAM AND DOWNSTREAM
 - SIDE ACCESS
 - NONE
- FACEGUARD LOCATION:
- DOWNSTREAM
 - UPSTREAM
 - UPSTREAM AND DOWNSTREAM
 - NONE
- ADDITIONAL FACTORY TESTING REQUIREMENTS:
- LEAK SCAN TESTED 99.97% HEPA MODEL
 - ** NO EFFICIENCY TESTING REQUIRED - MEDIA MANUFACTURERS RATING ACCEPTABLE
 - CERTIFIED TEST LABEL AT _____ EFFICIENCY

** Note: Testable HEPA & ULPA grade filters are tested for 0.3 micron EFFICIENCY at rated airflow unless NO EFFICIENCY TESTING is specified (Option 2, above)

** Note: 99.99 & above are always leak scanned.

*** STANDARD DEPTHS: 5-7/8" AND 11-1/2"

Customer Notes / Additional Requirements

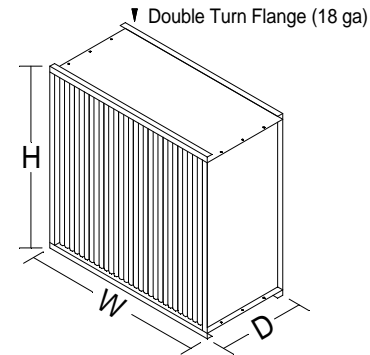

Height x Width x Depth
ALL DIMENSIONS ARE ACTUAL SIZE

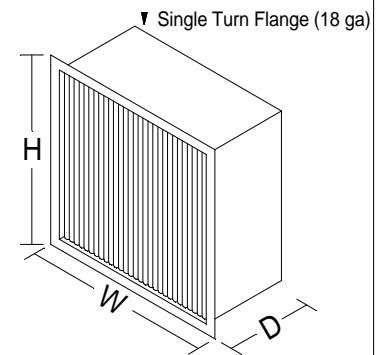

Height* x Width* x Depth
* of FLANGE
ALL DIMENSIONS ARE ACTUAL SIZE

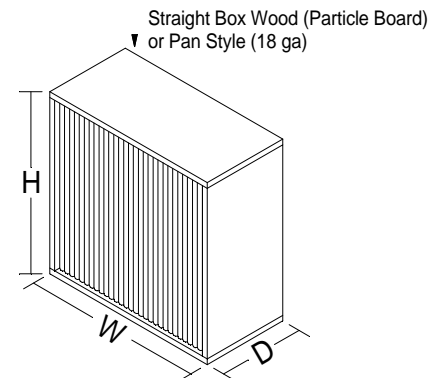

Height x Width x Depth
ALL DIMENSIONS ARE ACTUAL SIZE

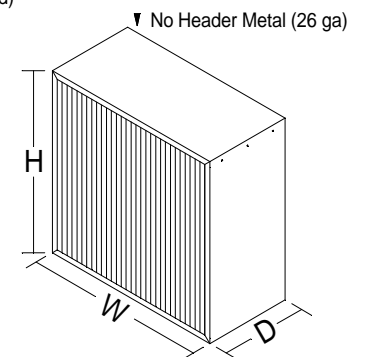

Height x Width x Depth
ALL DIMENSIONS ARE ACTUAL SIZE

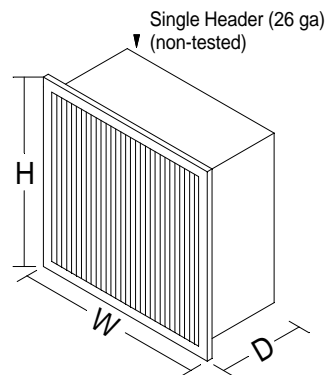

Height* x Width* x Depth
* HEADER
ALL DIMENSIONS ARE ACTUAL SIZE

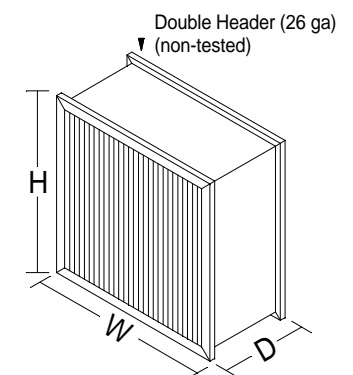

Height* x Width* x Depth
* HEADER
ALL DIMENSIONS ARE ACTUAL SIZE



Koch Filter Corporation
Filtration Products Crafted with Pride
P.O. Box 3186 - Louisville KY 40201
625 W. Hill Street - Louisville KY 40208
Phone: (502) 634-4796 FAX: (502) 637-2280

BIOMAX FILTER SUBMITTAL